

Dean Pump® Self-Priming Chemical Process Pumps

pHP Series



pHP Self Primer - 2 Pole

3500 RPM

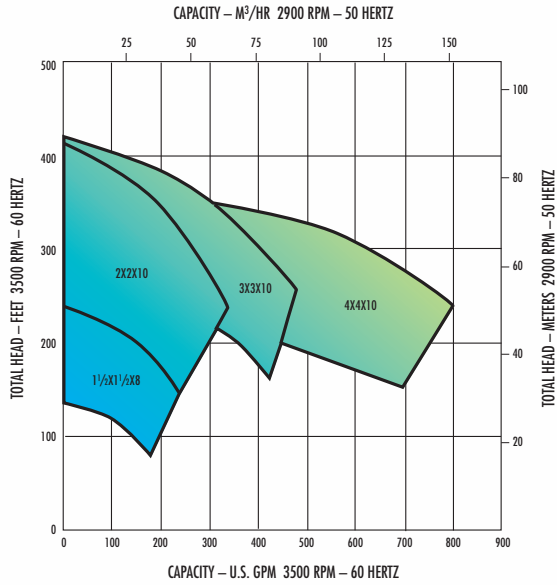

pHP Self Primer - 4 Pole

1750 RPM

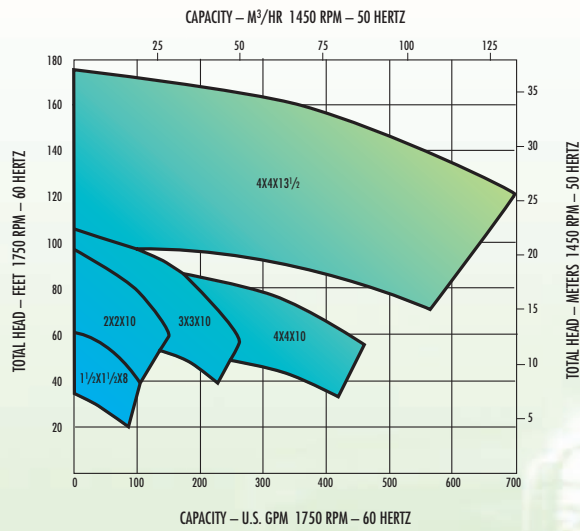

Maximum Allowable Working Pressure

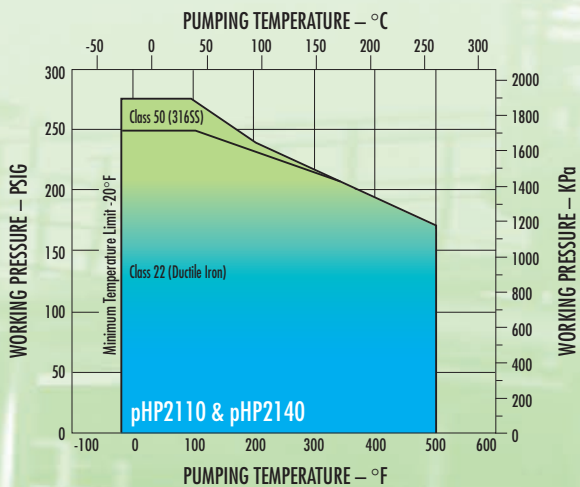

PERFORMANCE SERIES PUMPS

Dean Pump® Series pHP Self-Priming Chemical Pumps

- Capacities to 700 GPM (160 m³/hr)
- Heads to 400 feet (120 m)
- Pumping temperatures to 500°F (260°C)
- Working pressures to 275 PSIG (1,896 kPa)

Principles of Operation

A self-priming pump is one in which the impeller, operating in the priming liquid, removes the air from the pump suction line. This results in a vertical rise of the process fluid in the suction line from a source below the pump. Once sufficient air is thereby removed, the process fluid flows into the pump and the pump primes. The vertical rise of the liquid is called "lift". The removal of air from the suction piping permits pressure, acting on the liquid surface of the source tank, to push the process fluid up into the pump. Usually the source is at atmospheric pressure, which provides a theoretical lift of 34 feet at sea level; however, the practical lift limit is 20 feet.

If the liquid in the source tank is at such an elevated temperature that vacuum pulled in the suction line causes the liquid to flash to vapor in the suction line, the pump cannot prime.

A self-priming pump requires liquid in the casing to achieve the priming action. An initial prime is accomplished by filling the pump casing with liquid through the priming hole in the top of the casing. The pump is then started and allowed to prime. The pump may be turned off and reprimed thereafter with the liquid retained in the special pump casing.

The action inside the pump during priming is one of air entrainment and larger bubbles passing with the priming liquid through the upper volute educer passage. The air separates out of this liquid in the upper chamber of the casing. This liquid returns to the entry port in the lower volute section and is recycled back into the impeller.

This action continues until sufficient air has been expelled to allow the pump to prime. Once prime is established, the pump operates just like a standard centrifugal pump.

During the priming cycle, there must be no air leaks in the suction piping or the shaft sealing device. Leakage of air into the system may prevent the pump from achieving prime.

When the pump prime is broken, the liquid in the suction pipe flows back into the liquid suction source. There may be a siphon effect, greater or lesser, depending on height, liquid and velocity. Although this pulls more liquid from the casing, there is always sufficient liquid retained in the pHP casing to start the priming cycle again. Thus, repriming can occur.

A self-priming pump is not a cure for an NPSH problem. The NPSH required by the pump is necessary for the pump to continue operating. A self-priming pump will handle occasional periods of vapor or air and will recover, but the NPSH required by the pump

must be provided. This will depend upon the amount of lift required and the vapor pressure of the fluid being pumped.

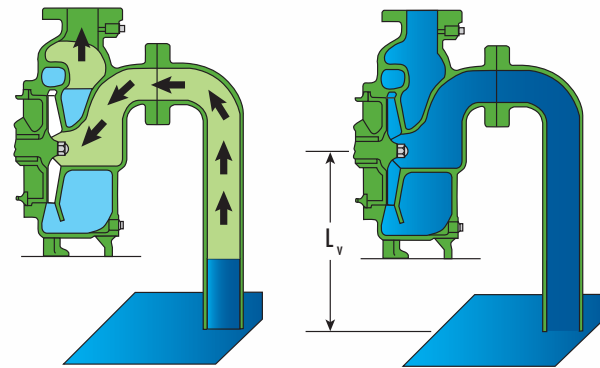

Priming Time Calculation

- Determine the effective suction lift. (Multiply vertical suction lift by specific gravity).
- Refer to the priming time curves. Using the effective suction lift, enter the priming time curve, read across to the impeller diameter selected and down to the priming time.

This is the priming time if the suction line is the same size as the suction flange and is all vertical lift without horizontal component.

To correct priming time for a different size of suction line and/or horizontal piping, use the formula below:

- t_{pc} = corrected priming time in seconds
- t_p = priming time from curve
- L_t = total length of suction pipe above the liquid surface in feet
- L_v = vertical height from surface of liquid to centerline of pump
- D = diameter of suction pipe, nominal, in inches
- d = pump suction size, nominal, in inches

$$t_{pc} = t_p (L_t/L_v) (D/d)^2$$

EXAMPLE

Assume:

- Vertical lift (L_v) = 20 feet
- Total length of suction pipe (L_t) = 40 feet
- Priming time (t_p) = 42 seconds
- Suction line D = 4" nominal diameter
- Suction flange d = 3" nominal diameter

Then:

$$t_{pc} = 42 (40/20) (4/3)^2 = 149.3 \text{ seconds}$$

Heating of priming liquid can reduce the maximum lift, but usually the NPSH above the vapor pressure requirement for the

operating point has long been exceeded. The heating of the priming liquid is of the magnitude of 10°F per minute.

To illustrate:

3 x 3 x 10, pHP2140, 3550 rpm, full diameter
Lift of 20 feet in 3" pipe
Water @ 80°F

From the priming time curve for the 3 x 3 x 10, pHP2140, the priming time is 32 seconds.

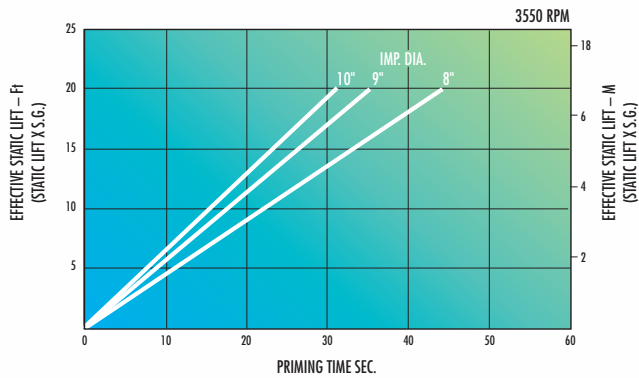

Priming at 20 feet requires an absolute pressure at the pump eye to be (34 feet - 20 feet), or 6.06 psia. From the steam tables, water boils at this pressure at about 170°F. The allowable maximum temperature rise in the priming liquid is (170°F - 80°F), or 90°F. At a temperature rise of 10°F per minute (60 seconds) the pump could run for nine minutes (540 seconds). Putting this time back into the priming time formula gives:

$$t_{pc} = t_p \left(\frac{L_t}{L_v} \right) \left(\frac{D}{d} \right)^2$$

$$540 \text{ sec.} = 32 \text{ sec.} \left(\frac{L_t}{20} \right) \left(\frac{3}{3} \right)^2$$

$$\text{Max. } L_t = \frac{540 \text{ sec.} (20) (1)}{32}$$

$$\text{Max. } L_t = 337 \text{ ft.}$$

Insure that max. $L_t \geq$ actual L_t

In applying a self-priming pump, consideration of the discharge piping is necessary. The air from the pump casing must be expelled without being compressed substantially above atmospheric pressure. Although a self-priming pump will prime against a small discharge pressure, the priming time will increase. However, if the pressure in the discharge line is too high, the pump will not achieve prime.

If the pump expels air into an empty discharge system, there is more than adequate volume available to contain the discharged air. If the discharge line contains a check valve, the check valve should be placed a minimum of one half times L_t away from the pump discharge to provide adequate volume, provided that the suction and discharge lines are the same size as the flanges on the pump. Caution should be taken to insure that the available volume in the discharge line is at least 50% of the suction line volume to be evacuated.

Another priming solution would be to install a valved line from the pump discharge system back to the suction source. This is left open during the priming cycle and closed when priming is accomplished and during pumping. With this arrangement, a check valve must be installed in the pump discharge line downstream of the bypass connection.

MECHANICAL DESIGN SPECIFICATIONS

PUMP TYPE	pHP2110	pHP2140
Direction of Rotation (Viewed from Coupling End)	CW	CW
Horsepower Rating @ 3500 rpm @ 1750 rpm @ 1150 rpm	35 HP 15 HP 10 HP	100 HP 40 HP 30 HP
Hydrostatic Test Pressure Class 22-50	430 psig	430 psig
Corrosion Allowance	1/8"	1/8"
Impeller Balance	Single Plane Dynamic Balance	
Flanges ANSI Class Facing - standard - optional	150 E.F. R.F.	150 E.F. R.F.
Finish	125 Ra	125 Ra
Stuffing box jacket pressure maximum	125 psig	125 psig
Bearing housing cooler pressure maximum	125 psig	125 psig
Maximum Suction Pressure	275 psig	275 psig
Bearings: Thrust Bearing Radial Bearing Lubrication	5306 6207 Oil	5309 6309 Oil
Seal Chamber Dimensions: Tapered Seal Chamber Length (Depth) Inside Diameter (Bore) Shaft Sleeve Diameter	2 3/8" 2 1/8" 1 3/8"	3 1/16" 3 1/2" 1 3/4"
Cylindrical Seal Chamber Length (Depth) Inside Diameter (Bore) Shaft Sleeve Diameter	1 7/8" 2 1/8" 1 3/8"	2 1/4" 3 1/2" 1 3/4"
Stuffing Box Dimensions: Length (Depth) Inside Diameter (Bore) Shaft Sleeve Diameter Lantern Gland Width	2 1/8" 2" 1 3/8" 7/16"	2 3/4" 2 1/2" 1 3/4" 5/8"
Packing Size - Square Number of Rings with Lantern Ring Number of Rings without Lantern Ring Spacing with Lantern Ring	5/16" 5 6 2-G-3	3/8" 5 7 2-G-3
Pump Shaft Dimensions: Span Between Bearings Span Between Radial Bearing and Impeller Diameter Under the Sleeve Diameter with No Sleeve Diameter at Coupling Diameter at Bearings Diameter at Impeller	3 15/16" 5 13/16" 1 1/8" 1 3/8" 7/8" 1 1/2" 3/4"	6 3/8" 7 7/8" 1 1/2" 1 3/4" 1 1/8" 2 1/8" 1 1/4"
L/D Ratio Sleeved Shaft Solid Shaft (No Sleeve)	123 55	96 52

STANDARD MATERIALS OF CONSTRUCTION

PART NO.	PART NAME	DUCTILE IRON	316SS
3	Impeller	C.I. (1)	316SS (12)
5	Casing	D.I. (10)	316SS (12)
5A	Casing Drain Plug	1020 Steel	316SS
5D	Casing Capscrew		Steel (11)
7	Cradle Spacer	①	D.I. (13)
7G	Spacer to Brg. Hsg. Capscrew	①†	1020 Steel
9	Bearing Housing Foot	①	C.I. (1)
10	Shaft Sleeve	▲†	316SS
10K	Sleeve Key	▲†	304SS
13	Seal Chamber Gland	Steel	316SS
14	Gland Stud		304SS
15	Gland Nut		304SS
17	Lantern Ring	▲†	Teflon ■
22	Casing Back Cover	D.I. (10)	316SS (12)
22A	Back Cover to Cradle Capscrew	▲†	1020 Steel
25	Radial Bearing	▲†	—
25A	Thrust Bearing	▲†	—
26	Bearing Housing	▲†	D.I. (13) C.I. (1)
27	Seal Ring	①†	C.I. (1)
28	Bearing End Cover	▲†	C.I. (1)
28A	Bearing End Cover Capscrew	▲†	1020 Steel
28B	End Cover Adjusting Screw	▲†	1020 Steel
28C	Adjusting Screw Locking Nut	▲†	1020 Steel
29	Pump Shaft	▲†	Steel (5)
31	Thrust Bearing Lock Nut	①†	1020 Steel
31A	Thrust Bearing Lock Washer	①†	1020 Steel
75A	Tapered Retaining Ring	②▲	Steel
75B	Large Retaining Ring	▲†	Steel
76	Labyrinth Seal - Front	▲†	Bronze & Viton ■
76A	Labyrinth Seal - Rear	▲†	Bronze & Viton ■
77	Casing Gasket		Teflon ■
77A	Impeller Gasket	▲†	Teflon ■
77B	End Cover Gasket	▲†	Buna (7)
80	Vent	▲†	—
95A	Mechanical Seal Stationary	▲†	
95B	Mechanical Seal Rotary	▲†	
109	Oil Cooler Assembly	▲†	SS Tubing with Steel Fins and Steel Fittings

① pHP2140 only ▲ Denoted parts are interchangeable in all pHP2110 and pHP2110 pumps
② pHP2110 only † Denoted parts are interchangeable in all pHP2140 and pHP2140 pumps
■ Registered Trademark of the E.I. DuPont Company

(1) Cast Iron (11) Steel: ASTM #A449
(5) Alloy Steel: 125,000 TS, 100,000 YP (12) 316SS: ASTM #A744 Grade CF-8M
(7) Buna "N" Rubber (13) Ductile Iron: ASTM #A536
(10) Ductile Iron: ASTM #A395

pHP2110

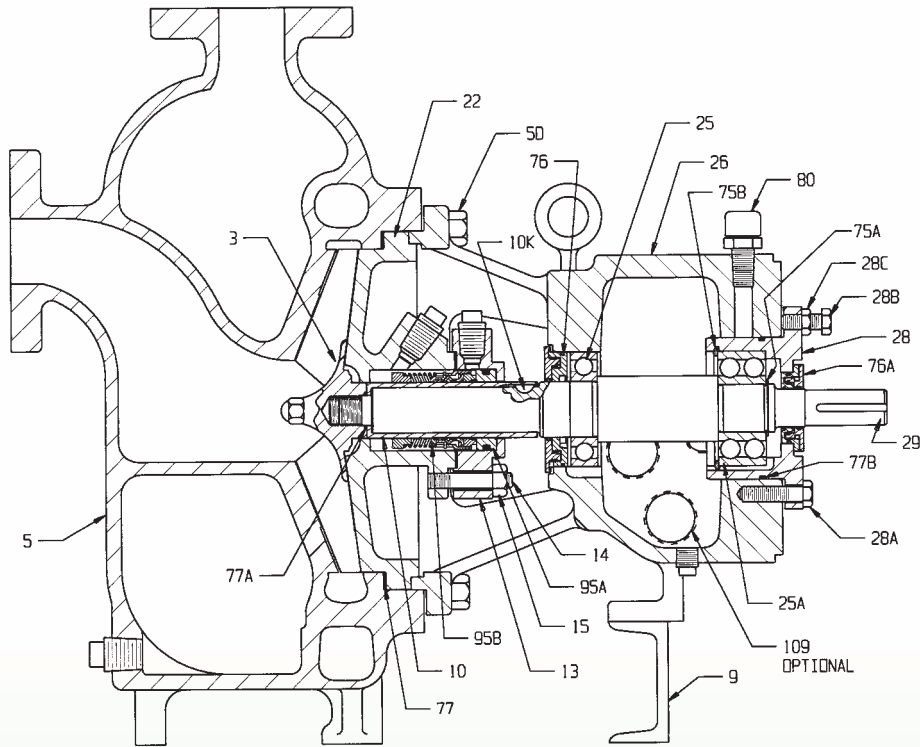

pHP2140

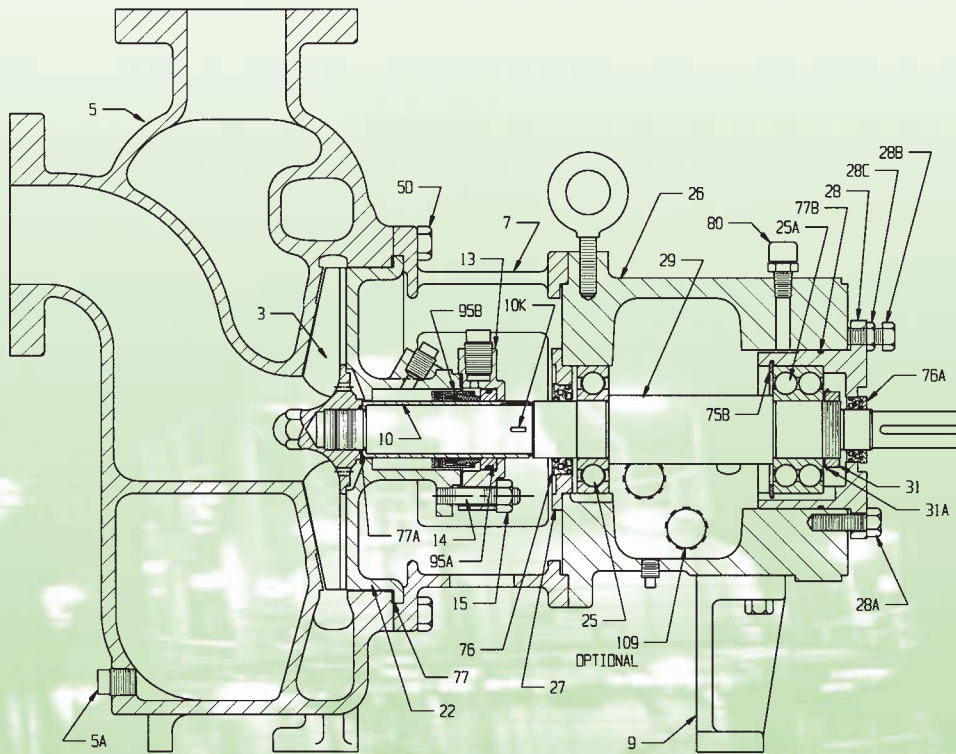

Dimensions with "Economy" Baseplate

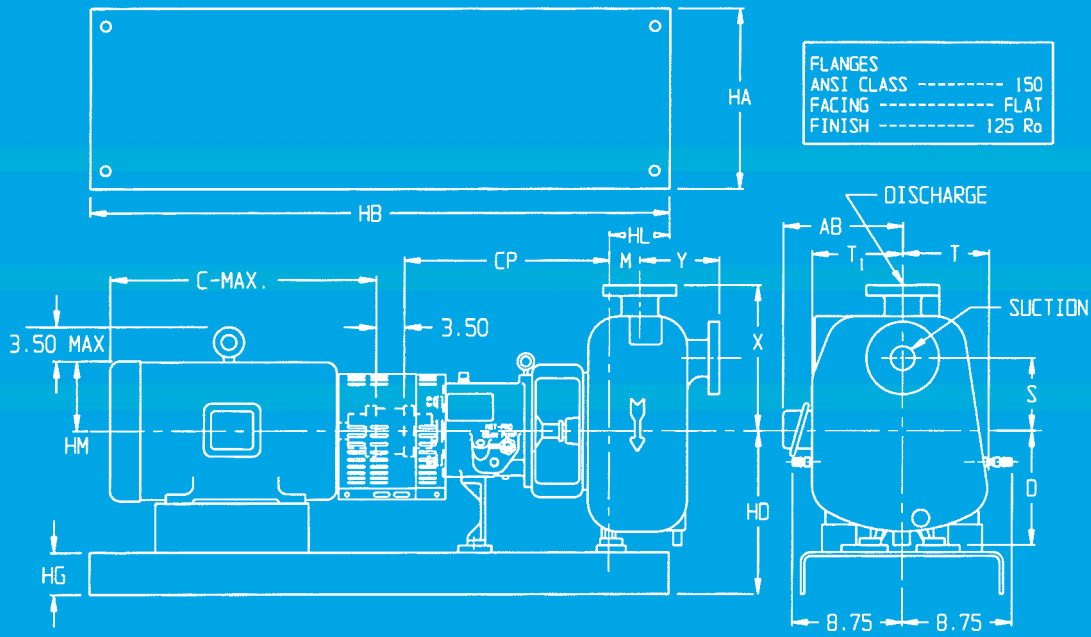

PUMP SIZE	DISCHARGE					SUCTION				
	SIZE	O.D.	THICKNESS	B.C.	BOLTS	SIZE	O.D.	THICKNESS	B.C.	BOLTS
1 1/2 x 1 1/2 x 8	1 1/2	5	.688	3.88	4-1/2	1 1/2	5	.688	3.88	4-1/2
2 x 2 x 10	2	6	.750	4.75	4-5/8	2	6	.750	4.75	4-5/8
3 x 3 x 10	3	7.50	.938	6	4-5/8	3	7.50	.938	6	4-5/8
4 x 4 x 10	4	9	.938	7.50	8-5/8	4	9	.938	7.50	8-5/8
4 x 4 x 13 1/2	4	9	.938	7.50	8-5/8	4	9	.938	7.50	8-5/8

PUMP SIZE	D	M	S	T	T ₁	X	Y	CP	HL
1 1/2 x 1 1/2 x 8	8.25	2.50	4.0	8.0	6.75	10	6.0	13.25	10.75
2 x 2 x 10	10	2.50	6.0	7.50	6.25	12	6.50	19.5	4.5
3 x 3 x 10	10	3	6.0	8.63	6.25	13	7	19.5	4.5
4 x 4 x 10	11.50	5	6.0	11.75	7.56	13	8	19.5	4.5
4 x 4 x 13 1/2	11.50	5.50	6.0	11.75	9.50	16	7.50	19.5	4.5

FRAME	C	AB	HA	HB	HD			HG	HM	FRAME	C	AB	HA	HB	HD			HG	HM
					D=8.25	D=10	D=11.5								D=8.25	D=10	D=11.5		
143T	13.25	6.50	12	45	12.0	13.75	15.25	3.75	3.88	286T	28.38	12.63	15	52	-	14.13	15.63	4.13	7.75
145T	13.75	6.50	12	45	12.0	13.75	15.25	3.75	3.88	286TS	27.00	12.63	15	52	12.38	14.13	15.63	4.13	7.75
182T	14.63	7.50	12	45	12.0	13.75	15.25	3.75	5.25	324T	29.88	14.75	18	58	-	14.75	16.25	4.75	8.75
184T	15.63	7.50	12	45	12.0	13.75	15.25	3.75	5.25	324TS	28.38	14.75	18	58	13.0	14.75	16.25	4.75	8.75
213T	18.13	9.50	12	45	12.0	13.75	15.25	3.75	6	326T	31.38	14.75	18	58	-	14.75	16.25	4.75	8.75
215T	19.63	9.50	12	45	12.0	13.75	15.25	3.75	6	326TS	29.88	14.75	18	58	-	14.75	16.25	4.75	8.75
254T	23.13	11.00	15	52	12.38	14.13	15.63	4.13	7	364T	33.13	16.25	18	58	-	14.75	16.25	4.75	9.88
256T	24.88	11.00	15	52	12.38	14.13	15.63	4.13	7	364TS	31.50	16.25	18	58	-	14.75	16.25	4.75	9.88
284T	26.88	12.63	15	52	-	14.13	15.63	4.13	7.75	365TS	32.50	16.25	18	58	-	14.75	16.25	4.75	9.88
284TS	25.50	12.63	15	52	12.38	14.13	15.63	4.13	7.75										

All dimensions are in inches.



A Met-Pro Fluid Handling Technologies Business
Combining the Resources of Dean Pump, Fybroc & Sethco

6040 Guion Road • Indianapolis, IN 46254
P: 317.293.2930 • TOLL-FREE: 800.801.9265 • F: 317.297.7028
info@deanpump.com • www.deanpump.com



© 2010 MET-PRO CORPORATION

DEAN PUMP® IS A REGISTERED TRADEMARK OF MET-PRO CORPORATION 09-5912 810

