

Dean Pump® High Temperature Air-Cooled Hot Oil Pumps

**No Water
Cooling
Required**

RA2096



RA3146



RA3186

Dean Pump® RA2096

The smaller, foot mounted economy version of the air-cooled RA series pumps.

- Available in three sizes.
- Bearing is double row thrust bearing, sealed design.
- Class 150 flat face flanges.
- Small size casings are subject to less thermal growth at higher pumpage temperatures allowing foot type construction.
- Dimensionally interchangeable with small ANSI B73.1 pumps.



RA2096 pump with base, coupling guard and motor. Economy (pre-1991 ANSI) and ANSI bases are available.

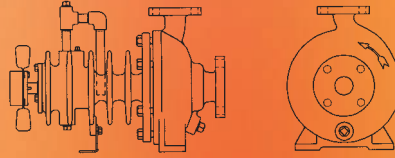

Dean Pump® RA3146

The larger, centerline mounted version of the air-cooled RA series pumps.

- Available in nine sizes.
- Dimensionally interchangeable with R4140 Series pump piping and baseplate dimension envelope.
- Thrust bearings are angular contact (pair).
- Class 300 raised face flanges.
- Centerline mounted casing minimizes thermal growth about the pump centerline without disturbing alignment. Rugged yoke mount casing support holds the pump securely in place resisting thermal expansion piping loads.
- Pumps can be mounted on ANSI B73.1 design baseplates.



RA3146 pump with base, coupling guard and motor.

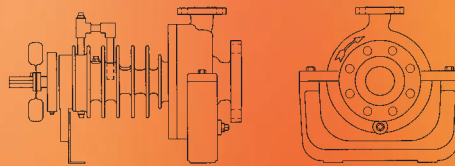

Dean Pump® RA3186

The largest, centerline mounted version of the air-cooled RA series pumps.

- Available in one size.
- Dimensionally interchangeable with R450 Series pump piping and baseplate dimension envelope.
- Thrust bearings are angular contact (pair).
- Class 300 raised face flanges.
- Centerline mounted casing minimizes thermal growth about the pump centerline without disturbing alignment. Pedestal mounted casing support holds the pump securely in place resisting thermal expansion piping loads.

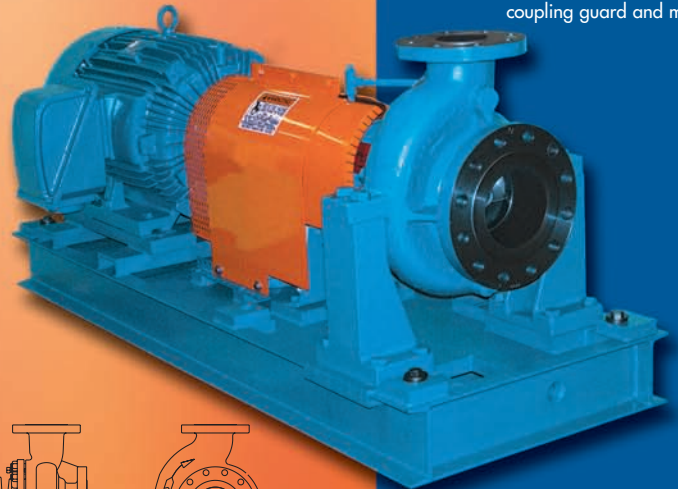

RA3186 pump with base, coupling guard and motor.

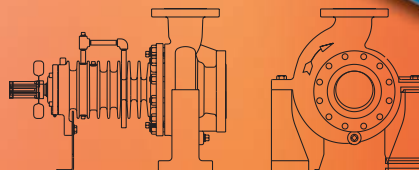

No Liquid Cooling Required

The air fan cooling design of RA Series pumps permits temperature drop in the pump from the casing to seal faces. When pumping at 650°F (343°C), the seal face temperature is less than 230°F (110°C). The efficient gradient breakdown protects the mechanical seal and bearing.

Heavy duty casing with top centerline discharge. Confined casing gasket.

Enclosed Francis vane impeller for efficient pump performance. Balance holes reduce axial thrust and extend bearing life.

Process fluid lubricated sleeve type radial bearing restricts high temperature liquids from the seal area and supports impeller radial load with L^3/D^4 ratio of 4.0.

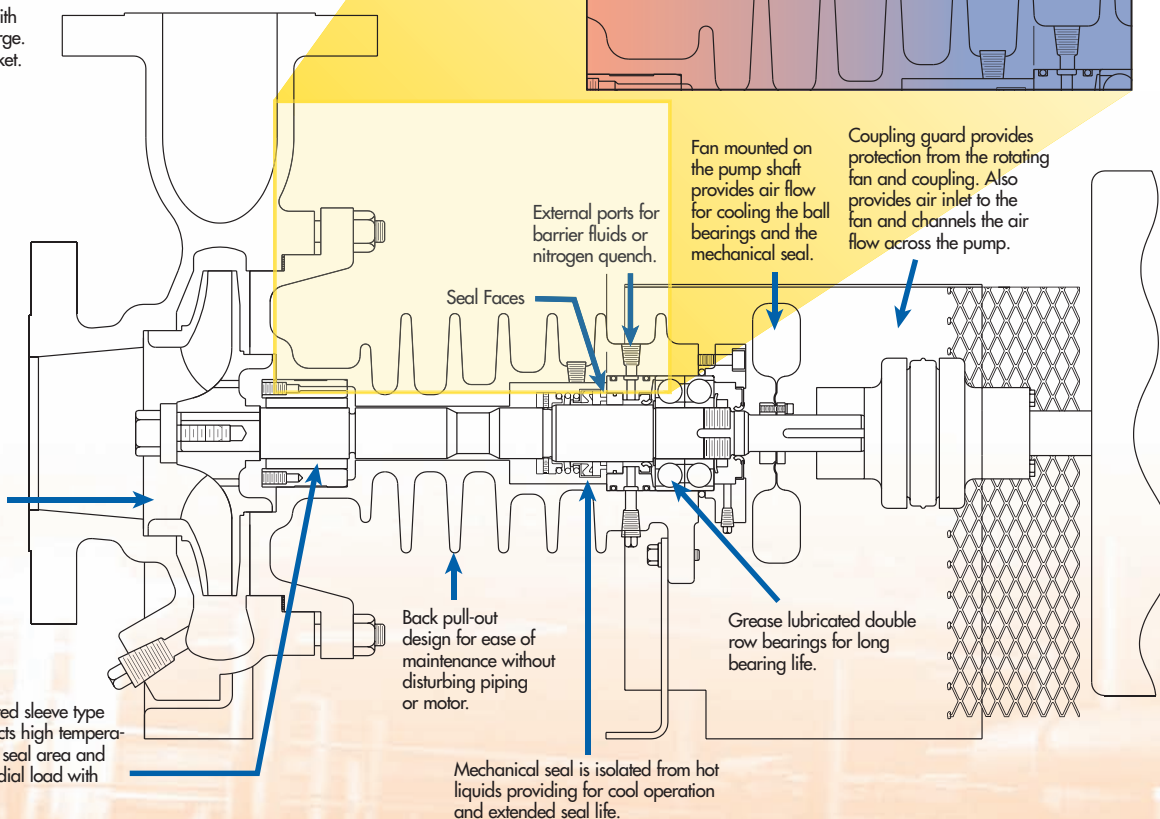

Experience

Dean Pump produced the first hot oil pump for the then growing process industry in 1931. The company has continued to provide rugged, field tested equipment which has set the industry's performance criterion. The RA Series pumps represent the highest quality and most cost effective heat transfer pumping equipment available today.

Dean Pump® Series RA Fan Cooled Pump Design

Centerline suction and discharge connections equalize pipe loads to prevent off-center forces and distortion. Connections are integrally cast with the pump casing. Totally confined casing gasket provides safety during all service conditions.

Back pull-out design, in conjunction with spacer type coupling, allows the entire rotating assembly to be removed for servicing without removing the casing from the piping or disturbing the driver for ease of maintenance.

Precision rabbeted joints on the casing and bearing housing allow accurate assembly and hold the assembled pump rigidly in-line.

All products are designed for maximum parts interchangeability. RA pumps are restricted to the use of heat transfer oils.

Fan Retro-Fit Kits* are available to convert older "RA" pumps to the new "Pump Shaft Mounted Fan" version.

Shaft Assembly and Exchange Kits* are available to obtain speedy repair of pumps with minimal down time.

*Consult factory for additional information.

HEAD/CAPACITY RANGE CHARTS

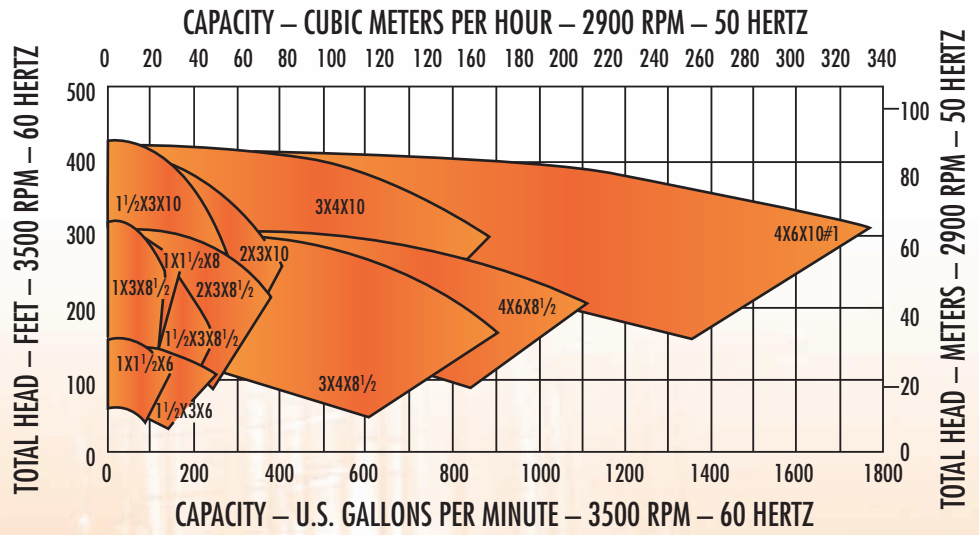
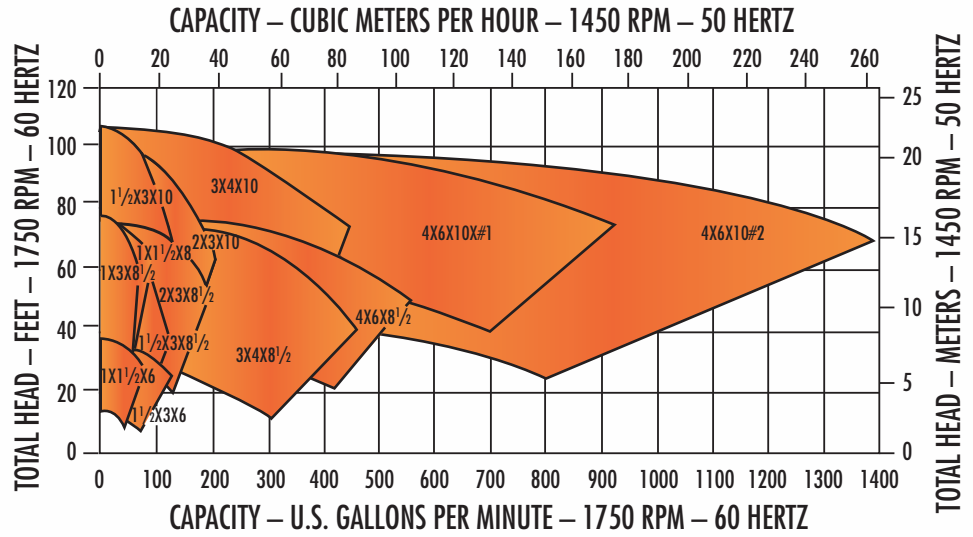

WORKING PRESSURE VS. PUMPING TEMPERATURE

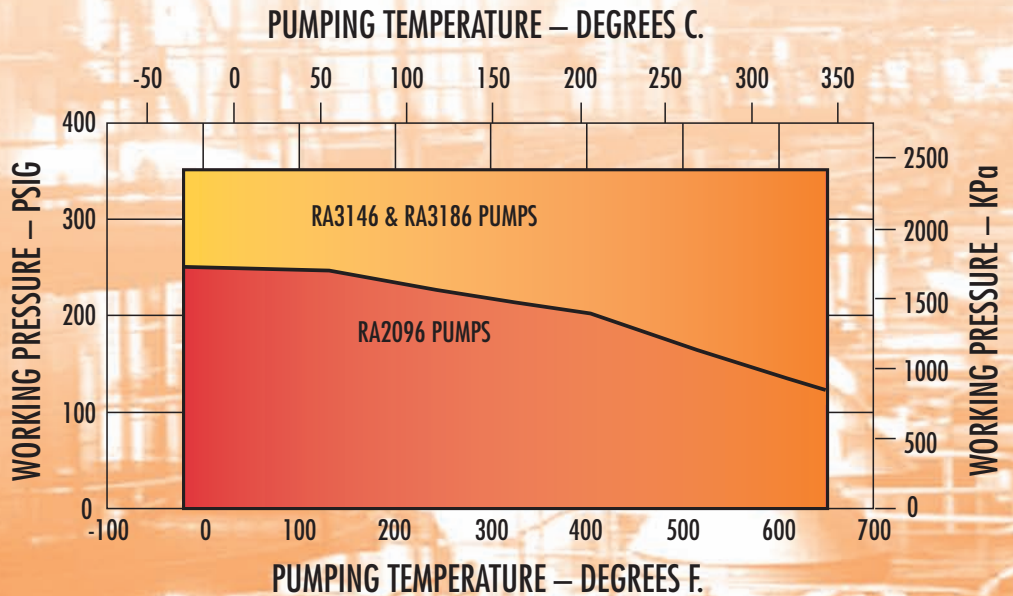

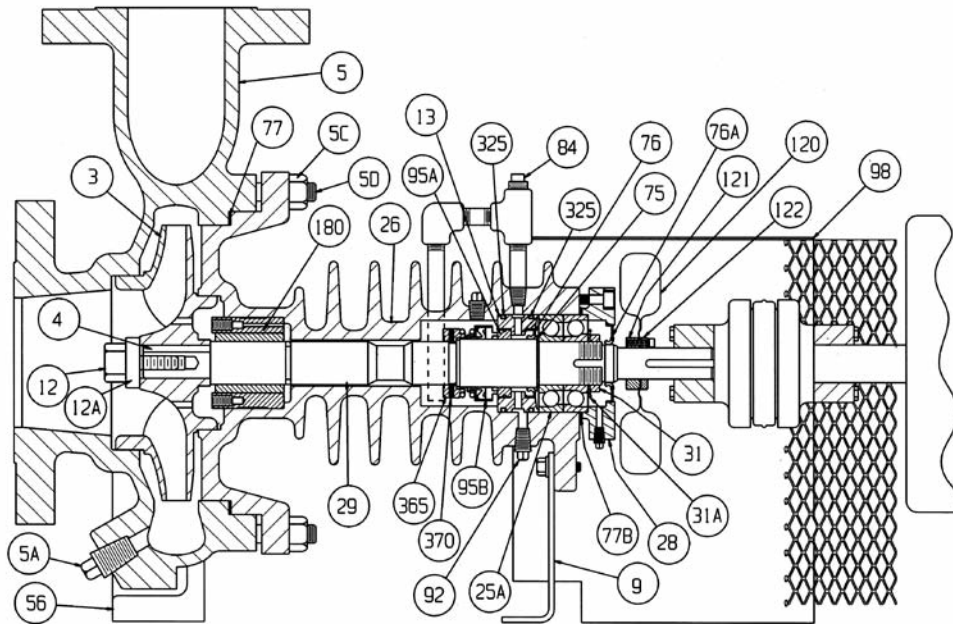

MECHANICAL DESIGN SPECIFICATIONS

PUMP TYPE	RA2096	RA3146	RA3186
Direction of Rotation (Viewed from Coupling End)	CW	CCW	CCW
Casing Thickness, Minimum	5/16"	5/16"	5/16"
Corrosion Allowance	1/8"	1/8"	1/8"
Impeller Balance Standard Optional Extra	Single Plane Dynamic	Single Plane Dynamic	Single Plane Dynamic
Flanges ANSI Class Facing Finish	150 Flat Face 125 Ra	300 Raised Face 125 Ra	300 Raised Face 125 Ra
Suction Pressure, Maximum	100 PSIG	100 PSIG	100 PSIG
Horsepower Rating, Maximum @3500 RPM @1750 RPM @1150 RPM	35 15 10	100 40 25	250 125 75
Bearings: Thrust Bearing, Ball Type, Grease Lubricated Radial Bearing, Sleeve Type, Pumpage Lubricated	5306 2RS Double Row	7308 BG Angular Contact Pair	7311 BG Angular Contact Pair
Seal Chamber Dimensions Length (Depth) Inside Diameter (Bore Dia.) Shaft Diameter	1 5/8" 2 1/16" 1 1/8"	2 13/16" 3 1/8" 1 3/4"	3 7/8" 4 5/16" 2 1/4"
Pump Shaft Dimensions Span Between Bearings Span Between Radial Bearing Centerline and Impeller Centerline Diameter at Coupling Diameter Between Bearings Diameter at Impeller	8 11/16" 1 5/8" 7/8" 15/16" 3/4"	11 7/16" 2 5/16" 1 1/8" 1 9/16" 1 1/8"	14 5/8" 3 1/4" 1 5/8" 1 7/8" 1 1/8"
L ² /D ⁴	4.3	2.1	2.8
Material Class	22 (Ductile Iron)	22 (Ductile Iron)	22 (Ductile Iron)
Maximum Working Pressure	250 PSIG @100°F	350 PSIG	350 PSIG
Pumping Temperature Minimum Maximum	-20°F @250 PSIG 650°F @125 PSIG	-20°F 650°F	-20°F 650°F
Maximum Ambient Temperature (temp. within 12" of pump)	104°F	118°F	118°F
Hydrostatic Test Pressure	430 PSIG	550 PSIG	550 PSIG

STANDARD MATERIALS OF CONSTRUCTION

Part No.	Part Name	RA2096 Class 22	RA3146 Class 22	RA3186 Class 22
3	Impeller	C.I. (1)	C.I. (1)	C.I. (1)
*4	Impeller Key	Steel (2)	Steel (2)	Steel (2)
5	Casing	D.I. (10)	D.I. (10)	D.I. (10)
5A	Casing Drain Plug	Steel (2)	Steel (2)	Steel (2)
5C	Casing Stud Nut	N.A.	Steel (5)	Steel (5)
5D	Casing Stud/Cap Screw	Steel (3) Screw	Steel (4) Stud	Steel (4) Stud
6A	Casing Ring (Only Some Sizes)	N.A.	Iron (7)	Iron (7)
9	Bearing Housing Foot	Steel (2)	Steel (2)	Steel (2)
*12	Impeller Bolt/Nut	Steel (2) Nut	Steel (2) Bolt	Steel (2) Bolt
*12A	Impeller Washer	Steel (2)	Steel (2)	Steel (2)
*13	Mechanical Seal Gland	Steel (2)	Steel (2)	Steel (2)
*25A	Shaft Bearing – Thrust – Ball	Double Row	Angular Contact Pair	Angular Contact Pair
26	Bearing Housing	D.I. (10)	D.I. (10)	D.I. (10)
*28	Bearing End Cover	C.I. (1)	Steel (2)	D.I. (9)
*29	Pump Shaft	11-13 S/S (12)	11-13 S/S (12)	11-13/316 S/S (8)
*31	Thrust Bearing Lock Nut	N.A.	Steel (2)	Steel (2)
*31A	Thrust Bearing Lock Washer	N.A.	Steel (2)	Steel (2)
56	Casing Foot	N.A.	C.I. (1)	C.I. (1)
*75	Snap Ring	N.A.	Steel (2)	N.A.
*75A	Snap Ring	Steel (2)	N.A.	N.A.
*76	Grease Seal – Front	Viton (13)	Viton (13)	Viton (13)
*76A	Grease Seal – Rear	N.A.	Buna (14)	Buna (14)
77	Casing Gasket	Grafoil (11)	Grafoil (11)	Grafoil (11)
*77B	Bearing End Cover Gasket	N.A.	Buna (14)	Buna (14)
*84	Barrier Oil Fill Plug	Steel (2)	Steel (2)	Steel (2)
*92	Barrier Oil Drain Plug	Steel (2)	Steel (2)	Steel (2)
*95A	Mechanical Seal Stationary	Silicon Carbide & Viton	Silicon Carbide & Viton	Silicon Carbide & Viton
*95B	Mechanical Seal Rotary	S/S, Carbon & Viton	S/S, Carbon & Viton	S/S, Carbon & Viton
98	Coupling Guard	Steel (2)	Steel (2)	Steel (2)
*120	Fan	Aluminum	Aluminum	Aluminum
*121	Fan Collar	N.A.	Steel (2)	Steel (2)
*122	Fan Clamp Ring	Steel (2)	Steel (2)	Steel (2)
*180	Radial Bearing Cartridge	Carbon & Steel	Carbon & Steel	Carbon & 416 S/S
*325	Seal Gland Gasket	Viton (13)	Viton (13)	Viton (13)
*365	Mechanical Seal Retainer	Steel (2)	Steel (2)	Steel (2)
*370	Seal Retainer Set Screw	Steel	Steel	Steel
*375	Anti-Rotation Pin	N.A.	N.A.	316 S/S

*Denotes parts interchangeability in all pump sizes of a given series.

(1) Cast Iron	(5) ASTM A194 Grade 2 Steel	(11) Grafoil®
(2) AISI 1020	(7) Hardened Iron	(12) ANSI – 420 S/S
(3) SAE Grade 5 or ASTM A449 Type 1 Steel	(8) ANSI 316 S/S with ANSI 416 S/S at the sleeve bearing	(13) Viton® Elastomer
(4) AISI 4140 ASTM A193-B7 Steel	(9) Ductile Iron – ASTM A536	(14) Buna N Rubber
	(10) Ductile Iron – ASTM A395	

Viton® is a registered trademark of E.I. DuPont Co.
Grafoil® is a registered trademark of Union Carbide Corp.

Dimensions

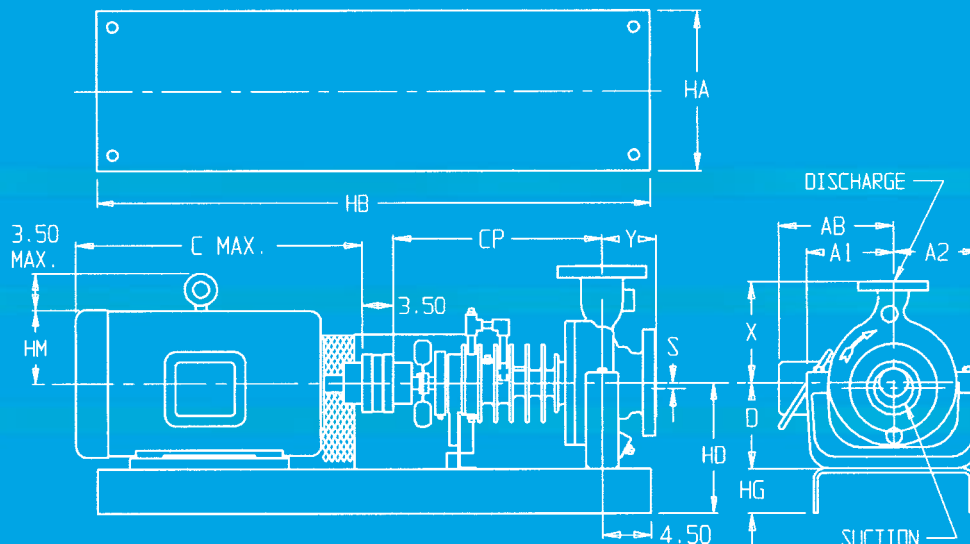

Dimensions Determined by Pump

Series	Pump Size	Suction			Discharge			A1	A2	D	S	X	Y	CP
		Size	Class	Face	Size	Class	Face							
RA2096	1x1 1/2x6	1.5	150	FF	1	150	FF	5.5	5.5	--	0	6.5	4	13.5
	1 1/2x3x6	3			1.5			5.5	5.5	--	0	6.5	4	13.5
	1x1 1/2x8	1.5			1			5.5	5.5	--	0	6.5	4	13.5
RA3146	1x3x8 1/2	3	300	RF	1	300	RF	8.13	8.13	8.25	0	7.50	4	19.5
	1 1/2x3x8 1/2	3			1.5			8.13	8.13	8.25	0	8.50	4	19.5
	2x3x8 1/2	3			2			8.13	8.13	8.25	0	9.50	5	19.5
	3x4x8 1/2	4			3			9.0	8.13	10.0	0	11.0	5	19.5
	4x6x8 1/2	6			4			10.25	8.13	10.0	.63	11.5	6	19.5
	1 1/2x3x10	3			1.5			9.0	8.75	10.0	0	9.0	4	19.5
	2x3x10	3			2			9.0	8.75	10.0	0	9.5	5	19.5
	3x4x10	4			3			10.38	8.75	10.0	0	11.0	5	19.5
4X6X10 #2	6	4	11.75	10	11.5	0.13	12.5	6	19.5					
RA3186	4X6X10 #1	6	300	RF	4	300	RF	12.25	10.50	12.0	0.25	12.0	6	26.0

Dimensions Determined by Electric Motor Frame Size

Frame Size	C (Max)	AB	HM	RA2096				RA3146			RA3186		
				HA	HB	HD	HG	HA	HB	HG	HA	HB	HG
140T	13.75	6.5	4.0	12	39	8.5	3.25	12	45	3.75	--	--	--
182T	14.63	7.5	5.25	12	39	8.5	3.25	12	45	3.75	--	--	--
184T	15.63	7.5	5.25	12	39	8.5	3.25	12	45	3.75	--	--	--
210T	19.63	9.5	6.0	12	39	8.5	3.25	12	45	3.75	--	--	--
250T	24.88	10.75	7.0	15	52	10.38	4.13	15	52	4.13	26	68	6.13
280T	28.38	12.63	7.75	15	52	11.13	4.13	15	52	4.13	26	68	6.13
320T	31.38	14.75	8.75	--	--	--	--	18	58	4.75	26	72	6.13
360T	34.13	15.63	9.88	--	--	--	--	18	58	4.75	26	72	6.13
400T	38.00	17.5	10.75	--	--	--	--	--	--	--	26	78	6.13
440T	40.50	18.5	12.25	--	--	--	--	--	--	--	26	82	6.13

All dimensions are in inches.



A Met-Pro Fluid Handling Technologies Business
Combining the Resources of Dean Pump, Fybroc & Sethco

6040 Guion Road • Indianapolis, IN 46254
P: 317.293.2930 • TOLL-FREE: 800.801.9265 • F: 317.297.7028
info@deanpump.com • www.deanpump.coms



© 2010 MET-PRO CORPORATION
DEAN PUMP® IS A REGISTERED TRADEMARK OF MET-PRO CORPORATION 09-5932 810

