

CORROSION RESISTANT 316 STAINLESS STEEL HORIZONTAL PUMPS

PARTS LIST

February 1, 1999

Supersedes PD-307-03A dated 1/1/83



Mailing Address: P.O. Box 12128, Hauppauge, New York 11788-0843

Shipping Address: 70 Arkay Drive, Hauppauge, New York 11788-3773

Tel: 516-435-0530 • Fax: 516-435-0654

Website: www.met-pro.com/sethco.html • www.thomasregister.com/sethco • e-mail: sethcosales@mindspring.com

West Coast Office: 230 N. Crescent Way, Unit I, Anaheim, CA 92801 • Tel: 714-991-0270 • Fax: 714-991-8107

MODEL SI-1/3

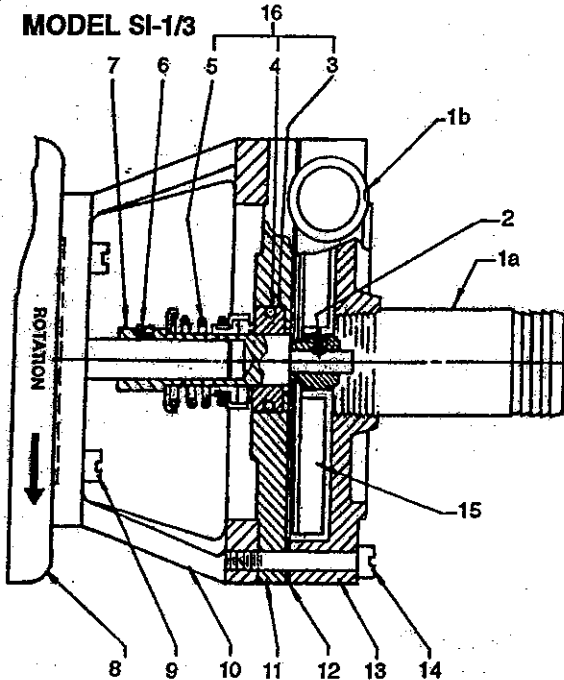

ITEM	QTY.	DESCRIPTION	MATERIAL	PART NUMBER
1a	1	Hose Adapter 1/2" x 3/4"	316SS	390P0406-670
1b	1	Hose Adapter 3/8" X 1/2"	316SS	390P0304-670
2	1	Set Screw	316SS	800P103202-670
3a	1	Stationary Seat	Ceramic	750P041-150
3b	1	Stationary Seat	Carperfter 20	750P041-130
4a	1	O-Ring	Hypalon	590P2210-341
4b	1	O-Ring	Viton	590P2210-830
5a*	1	Rotary Seal	Graphite-Neo	760P04-320
5b*	1	Rotary Seal	Graphite-Viton	760P04-310
5c**	1	Rotary Seal	Graphite-Teflon	760P04-777
6	2	Set Screw	Steel	800P103202-720
7	1	Shaft	316SS	850P04202-670
8	1	Motor	See TEFC Motors below	
9	4	Screw	Stainless Steel	790P103205-680
10	1	Motor Adapter	Ni-CI	010P11-500
11	1	Backplate	SS-316	670P04-670
12a	1	Gasket	Hypalon	330P403-341
12b	1	Gasket	Teflon	330P403-770
12c	1	Gasket	Viton	330P403-830
13	1	Volute	316SS	950P1303-670
14	6	Screw	Stainless Steel	790P1032102-680
15	1	Impeller	316SS	430P3021-670

COMPLETE MECHANICAL SEAL ASSEMBLIES (ITEM 3, 4 AND 5)

ITEM	QTY.	DESCRIPTION	ASSEMBLY	PART NUMBER
16a*	1	CM	3a, 4a, 5a	760P04-180
16b*	1	NM	3b, 4a, 5a	760P04-200
16c*	1	MC	3a, 4b, 5b	760P04-181
16d*	1	MN	3b, 4b, 5b	760P04-201
16e**	1	RC	3a, 4b, 5c	760P04-188
16f**	1	RN	3b, 4b, 5c	760P04-204

TEFC MOTORS

ITEM	DESCRIPTION	PART NUMBER
8a	115V, 50/60Hz, 1 phase	575P00H12311D40
8b	230V, 50/60Hz, 1 phase	576P00H12311D40
8c	230/460V, 50/60Hz, 3 phase (unwired)	574P00K36331D40
8d	1/3HP, 1 phase, explosion proof (unwired)	574P00L32311D50

CALL SETHCO OR A SETHCO DISTRIBUTOR FOR PRICES

* See Illustration 1
** See Illustration 2

SEE REVERSE SIDE FOR ASSEMBLY / DISASSEMBLY INSTRUCTIONS

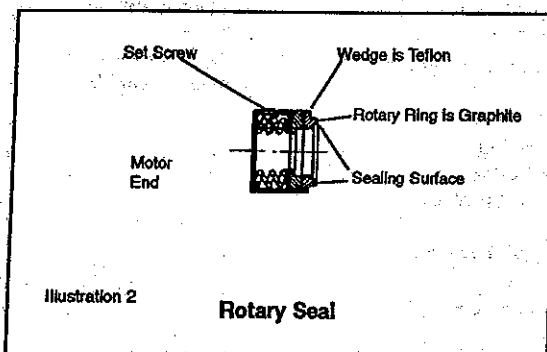
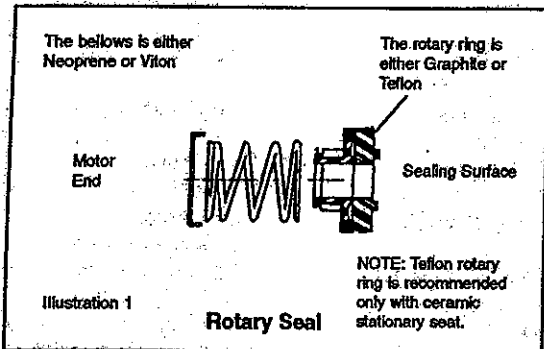

SETHCO CORROSION RESISTANT 316 STAINLESS STEEL HORIZONTAL PUMPS

MODEL S1-1/3

PRE-INSTALLATION

Before using your new Sethco pump, there is some background information that will be of value to you. All Sethco pumps are tested for proper operation. Before installing your new Sethco pump, the following is recommended:

1. Determine that the merchandise checks against the packing slip for completeness of order. If there is a discrepancy, please notify Sethco immediately—preferably by phone and also confirm by mail.
2. Check the pump for proper operation. This checkout cannot be as complete as an actual operational test; however, the following is suggested:
 - Visually check the pump assembly for shipping damage.
 - Determine if any objects are lodged in the pump.
 - Turn the shaft to determine that it is not bound.
 - Damage to the drive motor can result from an excessive load.
3. Examine mounting location for maintenance accessibility. After the hose has been connected and before the pump is installed, it is recommended that the system be flushed of dirt and plastic chips.

DISASSEMBLY

1. Loosen 6 screws (14) about 1/8" and tap volute (13) to separate it from the backplate (11).
2. Remove screws (14) and pump volute (13)
3. Loosen set screw (2) and remove impeller (15).
4. Remove backplate (11) by pulling straight out to clear the shaft.
5. Remove seat (3) and O-ring (4) pushing out by hand or by the eraser end of a pencil, being careful not to damage the lapped surface. Examine lapped surface for wear or scoring. If one side of seat is worn, use reverse side when replacing*. Always use new O-rings and be careful not to pinch O-ring when inserting into plate bore.
6. Remove the rotary seal (5) by sliding off shaft and inspect for wear. Close inspection may reveal wear, scoring or cracking of the graphite face.

*Ceramic seat has one lapped surface while Carpenter 20 seat has both sides lapped.

ALIGNING SHAFT

The alignment of the shaft at full run out should be checked before the pump is assembled. Proceed as follow:

1. Turn on motor
2. Position a pencil 90° to the running shaft and press pencil lightly on end of shaft just before thread.
3. Turn off motor. If shaft is fully aligned there will be a pencil mark all around the shaft. If the mark is on one side only, tap that side lightly with a plastic mallet or wood block.
4. Repeat test until pencil mark extends around the shaft.

REPLACING SEAL

1. Clean all pump sealing surfaces. Lubricate O-ring with water before pressing stationary seat and O-ring into plate bore; careful not to pinch O-ring.
2. Replace all parts by hand to prevent damage to lapped surfaces. If the seat is worn on one side only, it can be reversed*. It is advisable to replace the O-ring at this point.
3. Wet inside of rotary seal with water before pressing over shaft (7). Insert rotary seal with graphite ring facing out.

4. (Item #5e rotary seal only). After reassembly of pump place rotary seal against stationary seat with fingertips.

CAUTION, DO NOT EXERT PRESSURE ON ROTARY SEAL.

Tighten the set screws (6) to affix seal to shaft. Remove the compression pins.

As the carbon face wears, it will be necessary to periodically respace the rotary seal.

ASSEMBLY

Reverse the procedure outlined under disassembly.

PRIMING THE PUMP

1. Pump chamber and suction piping must be completely filled with fluid or pump will not prime. Check to be sure suction and discharge valves are open and suction piping is submerged in the fluid to be pumped. Start the pump.

SUCTION AND DISCHARGE PIPING

The suction pipe/hose must be secure and free of air leaks. This is particularly important when the suction line is a long one. A horizontal suction line should have a gradual rise to the pump. Any high point in the suction line will become filled with air and thus prevent proper operation of the pump. Discharge pipe/hose must be secured to prevent whipping, fatigue and accidental drainage.

TROUBLESHOOTING

NO DISCHARGE

- Pump not primed
- Speed too low
- System head too high
- Suction lift higher than that for which pump is designed
- Impeller or suction completely plugged
- Wrong direction of rotation
- Air leak in the suction line

INSUFFICIENT DISCHARGE

- Air leaks in suction
- Speed too low
- System head higher than anticipated
- Insufficient NPSHA
- Impeller or suction partially plugged
- Impeller damaged
- Suction opening not submerged enough
- Wrong direction of rotation

INSUFFICIENT PRESSURE

- Speed too low
- System head less than anticipated
- Air or gas in liquid
- Impeller damage
- Impeller diameter too small
- Wrong direction of rotation

LEAKS

- Locate leak and inspect O-ring, gasket, or mechanical seal. Seal should be replaced as a set when required.

EXCESS POWER CONSUMPTION

- Speed too high
- System head lower than rating, pumps too much liquid
- Specific gravity or viscosity of liquid pumped is too high
- Mechanical defects:
 - Shaft bent
 - Rotating elements bind
- Low Voltage Supplied